

# chloriDOS iOX®

Safe, reliable & efficient on-site  
generation of chlorine dioxide

iOX®: 5, 10, 20, 40 g/h ClO<sub>2</sub>



## Function

chloriDOS® iOX® range of systems provide a batch supply of chlorine dioxide solution for on-demand chemical dosing & disinfection applications, generated from chlorite/acid chemical reagent process.

The iOX® automatically draws and mixes precise volumetrically measured amounts of acid and chlorite, under vacuum, from respective chemical storage containers from up to 50m away if required. The reacted chlorine dioxide solution is homogenised and diluted with a volumetrically controlled flow of cold water prior to dispensing into the integral storage tank under atmospheric pressure.

Retention time of the chlorite/acid mixing is continuously controlled within the generator and automatically diluted and dispensed into the product batch tank, the level of which is governed by electronic level sensors.

## Benefits

- Batch preparation and dosing apparatus all fully contained within a single, lockable unit.
- Safe handling of chemical reagents drawn from containers under vacuum.
- Vacuum process eliminates need of chemical reagent dosing pumps and associated loss of prime and pump head maintenance.
- Batch dilution volumetrically controlled.
- Reagent consumption precisely governed by volumetric flow sensors optimising chemical usage.
- A second and third dosing pump can be connected externally for multi-point dosing.
- Simple and low maintenance frequency.
- Low whole life costs.

## Features

- iOX® model range offers 5, 10, 20 and 40 g/h chlorine dioxide generation capacity.
- Durable and attractive plastic equipment cover with security lock facility.
- Easy to operate membrane keypad multi-lingual control panel & OLED display with green, amber and red LED operational status indicators.
- Operational parameters displayed with code protected programming.
- Alarm event log with real time clock recording.
- Volumetric measurement and data storage of chemical reagent consumption volumes and site water meter usage.
- Service Due & Reactor Replacement alert.
- Corrosion resistant PVDF valves and sensors.
- Modbus (optional) to monitor and alert chemical reagent usage, site water/process usage volumes, control status and data trending.
- Two-year product warranty.

## Areas of Application

- Combating legionella in water systems
- Food & beverage CIP disinfection
- Cooling tower biocide treatment
- Food washing / processing treatment
- Municipal potable water disinfection
- Secondary disinfection in public buildings
- Commercial swimming pool filter hygiene
- Odour control in waste processes

## Product Description

### iOX® Installation schematics

#### Single-point dosing

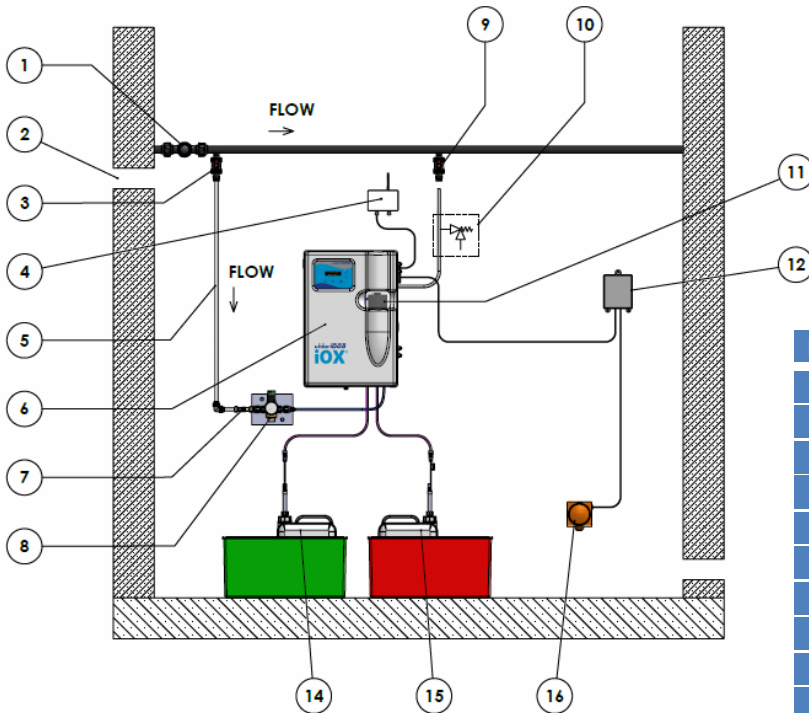

Item	Description
1	Site pulsed water meter (site)
2	Natural room ventilation (site)
3	Cold water feed isolation (site)
4	COMM's/telemetry (optional)
5	Cold feed pipe work (site)
6	iOX®I chlorine dioxide generator
7	Water supply double check valve (site)
8	Water pressure regulator/filter
9	ClO <sub>2</sub> dosing injection point
10	Dosing retention/relief (optional)
11	Internal ClO <sub>2</sub> dosing pump (optional)
12	Gas detect panel (optional)
13	External ClO <sub>2</sub> dosing pump (optional)
14	Acid reagent drum/tank (optional)
15	Chlorite reagent drum/tank (optional)
16	Gas sensor head (optional)

#### Multi-point dosing

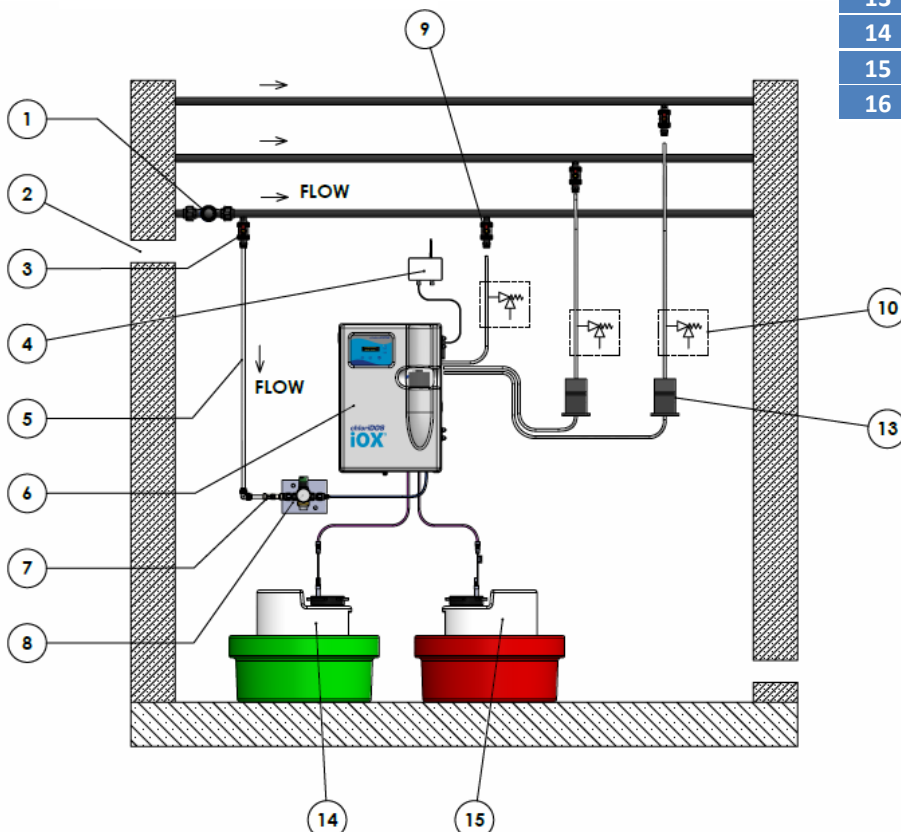

## Product Description

### iOX® Design Concept

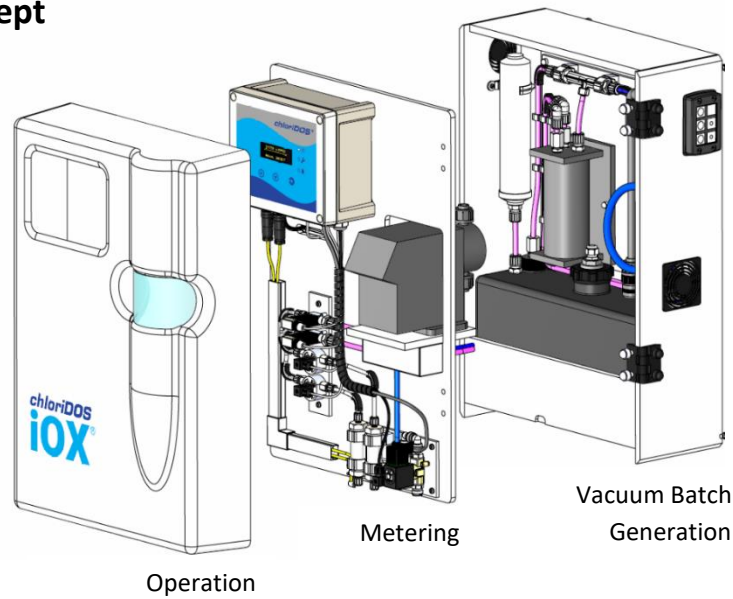

### Feature Equipment

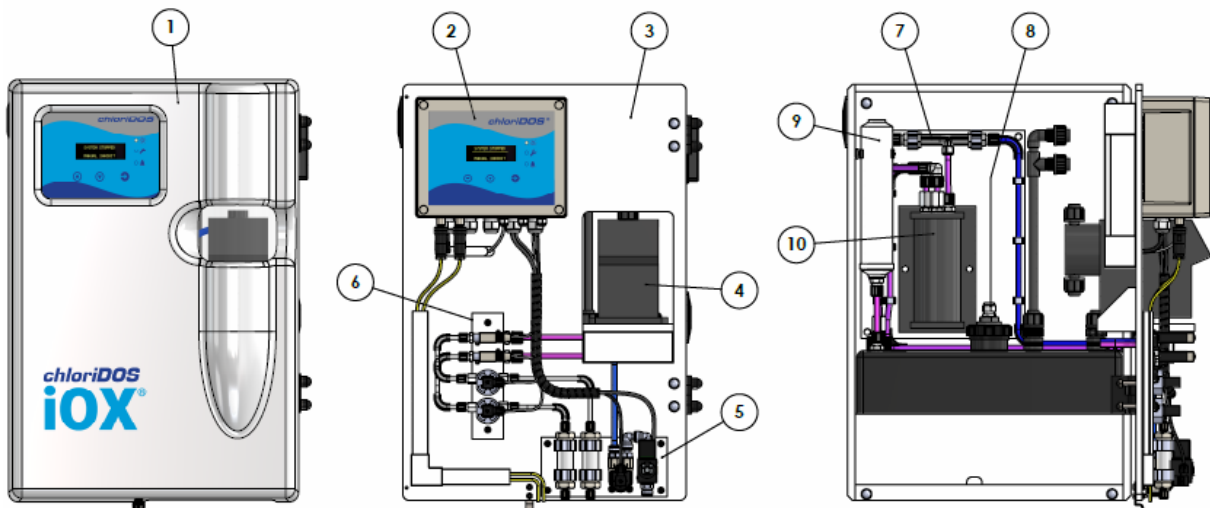

Item	Feature Equipment Description
1	iOX® plastic cover
2	chlariDOS® controller & OLED display
3	Hinged metering & control board assembly
4	Internal ClO <sub>2</sub> dosing pump (optional)
5	Dilution water flow control
6	Chemical reagent flow control
7	Reagent vacuum & dilution device
8	Batch tank level sensor device
9	Batch tank carbon air scrubber
10	ClO <sub>2</sub> reactor assembly
Item	Ancillary Equipment
1	Cold water supply pressure regulator/filter assembly
2	Dosing pump injection/isolation valve assembly

### Ancillary Equipment

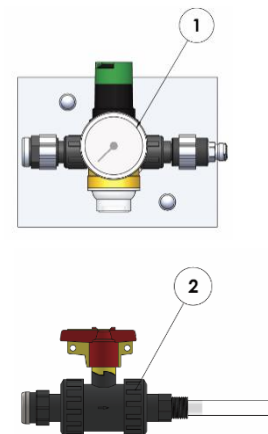

## Technical Specification

### iOX® Technical Data

Description	unit	chloriDOS® iOX® model capacity			
		5	10	20	40
Chlorine dioxide (ClO <sub>2</sub> ) capacity	g/h	5	10	20	40
ClO <sub>2</sub> generation strength	%	2*			
ClO <sub>2</sub> batch solution strength	mg/l	500	1000	1500	
ClO <sub>2</sub> batch solution production rate	l/h	9.5	10	13.5	26.9
ClO <sub>2</sub> batch tank nominal volume	l	8.5			
Power supply	∅	110 - 240VAC / ∅1 / 50-60Hz			
Power rating	VA	20			
Combined peak dosing pump output dosing pump(s) not included	l/h	15			30
Feed water pressure	Bar	2 to 8			
Nominal water consumption	l/h	9.6	9.4	12.4	24.8
Total reagent consumption 1:1 ratio	l/h	0.26	0.52	2.0	4.0
Protection class	IP	54			
Permissible ambient temperature	°C	5 - 35			
Permissible feed water temperature	°C	10 - 30			

\* precursor concentration (by weight): 9% HCl / 7.5% NaClO<sub>2</sub>

### iOX® Match-code System Build & Supply Information

Generator capacity				
G005	5g/h chlorine dioxide generator at 500mg/l ClO <sub>2</sub> solution			
G010	10g/h chlorine dioxide generator at 1000mg/l ClO <sub>2</sub> solution			
G020	20g/h chlorine dioxide generator at 1500mg/l ClO <sub>2</sub> solution			
G040	40g/h chlorine dioxide generator at 1500mg/l ClO <sub>2</sub> solution			
↓	Cover			
	C0	Grey cover hood		
	↓	Pump Configuration		
		P0	Without pump fitted	
		P1	With pump fitted	
	↓	Power Supply		
		V1	230Vac 50/60Hz	
G005	C0	P0	V1	Match code order example



## Dimensions & Weight

### iOX® Overall dimensions

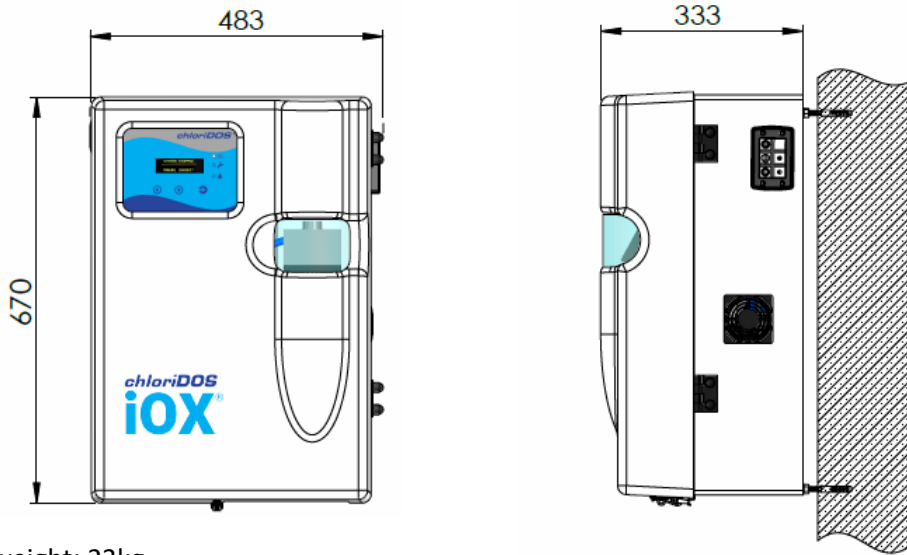

Shipping weight: 23kg

### Recommended installation arrangement dimensions

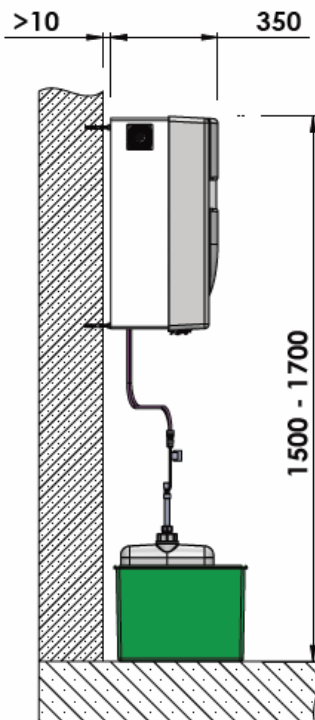

### Water PRV dimensions

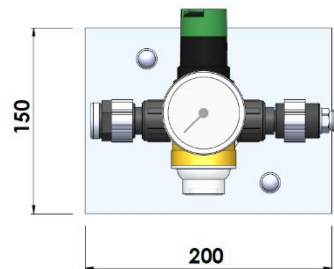

### Injection isolation valve dimensions

